

THIS INFORMATION IS CONFIDENTIAL AND IS DISCLOSED TO YOU ON CONDITION THAT NO FURTHER DISCLOSURE IS MADE BY YOU TO OTHER THAN TETULL PERSONNEL WITHOUT WRITTEN AUTHORIZATION FROM TETULL LTD.

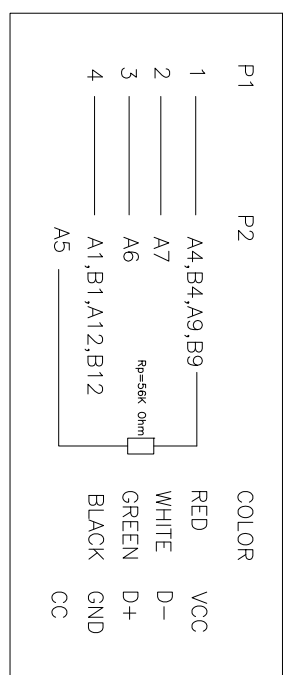
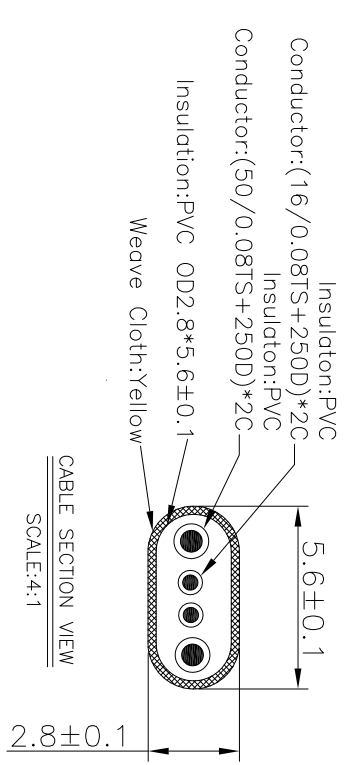
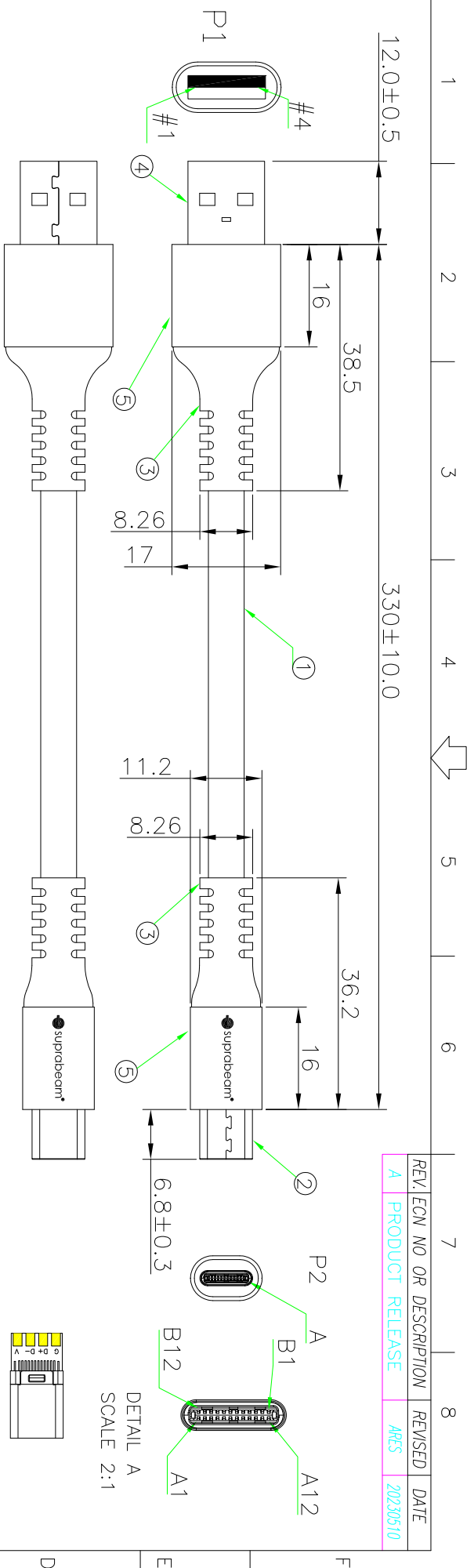

NOTE:

MATERIAL:

1. 织布面线条 OD:2.8*5.6 50/0.08TS+250D尼龙丝*2C PVC红白+16/0.08TS+250D尼龙丝*2C PVC白 PVC中被(黑色)+织布(P1143C)
2. Connector: USB C-TYPE/M SOLDER TYPE,T:Au 1u",Shell:Steel,Nickel Plated
3. Mold Material: 45P PVC, Color: Black.
4. Connector:USB A/M Solder Typ.;Shell:Spec,Nickel plated;Terminal:G/F
5. Al alloy shell:Anodization.Color:Black.

Electrical Test Conditions:

1. Conduction Test:100% qualified,No Open/Short circuit phenomenon
2. Voltage:DC 5V
3. Maximum endurance current:2.0A Max

REV.	ECN NO.	OR DESCRIPTION	REVISED	DATE
A	PRODUCT RELEASE		AMS	20230510

UNLESS OTHERWISE SPECIFIED TOLERANCES

DECIMALS:	ANGLES:
X : ±0.5	X : ±2°
X.X : ±0.3	X.X : ±1'
X.XX : ±0.2	



TITLE: USB TYPE C TO USB AM 2.0 (3000(DATA CABLE))	
PART NO.	1120208AP009
DWN	JAMES
CHKD	20230510
APVD	
SCALE 1:1	UNIT: mm
SIZE: A4	SHEET: 10/1
	REV: A