

THIS INFORMATION IS CONFIDENTIAL AND IS DISCLOSED TO YOU ON CONDITION THAT NO FURTHER DISCLOSURE IS MADE BY YOU TO OTHER THAN TETULL PERSONNEL WITHOUT WRITTEN AUTHORIZATION FROM TETULL LTD.

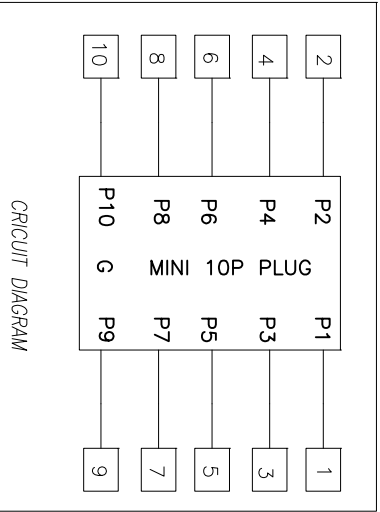

D	PCB	1	FR4-1
C	SHELL	1	SPEC 0.30t
B	CONTACT	10	C5191 0.20t
A	HOUSING	1	LCP

UNLESS OTHERWISE SPECIFIED TOLERANCES		DECIMALS:		ANGLES:	
X	:±0.5	X	:±2°	X	:±1'
X	:±0.3	X		X	
X	:±0.2	X		X	

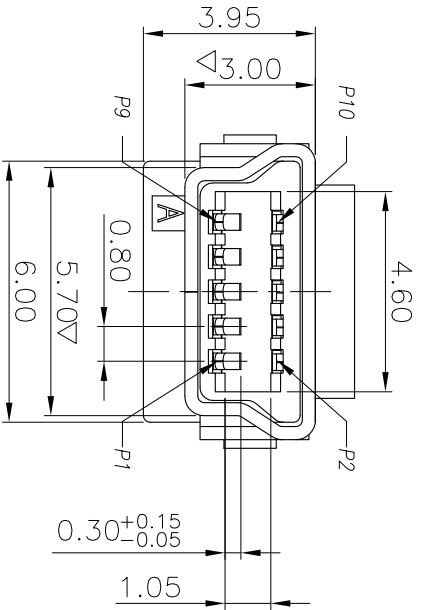
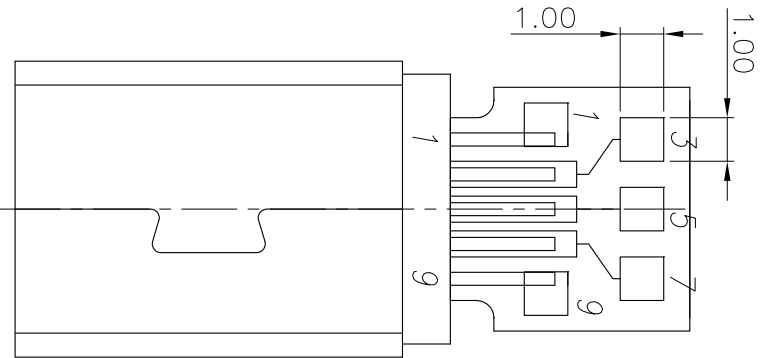
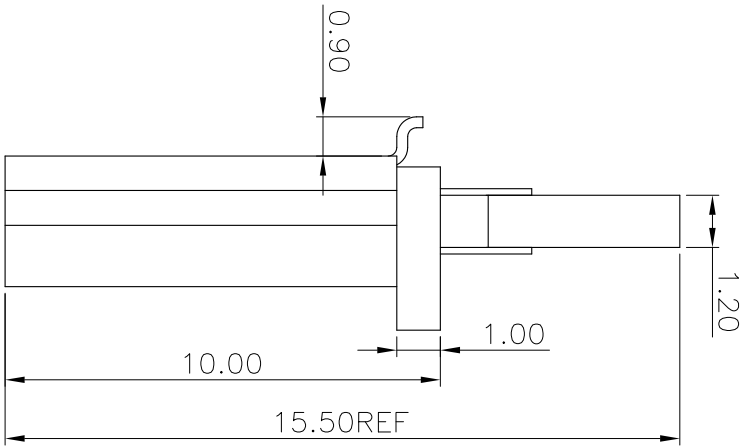
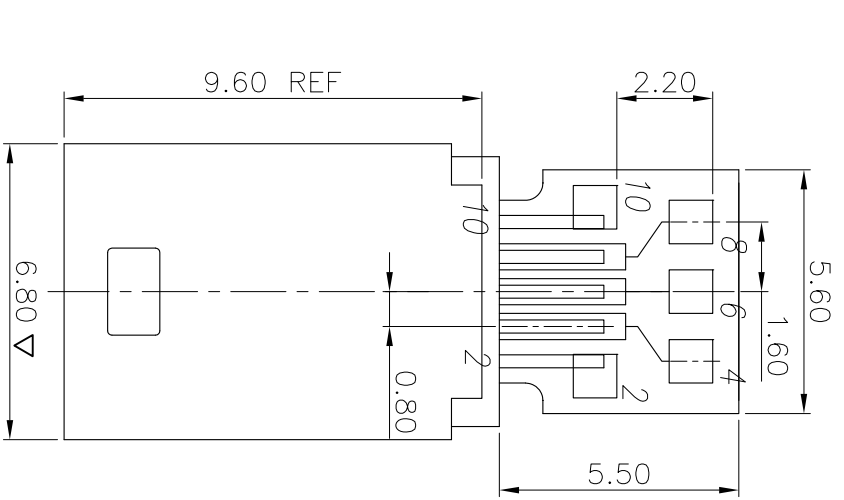
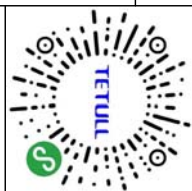

TITLE:	MINI 10P公头绿壳(镀光亮无脚)=1.5, 5 (10位)小板
PART NO.	1031002GR068
DWG	BROKEN
CHKD	
APVD	
SCALE 1:1	UNIT: mm
SIZE: A4	SHEET: 10F1
CUSTOMER COPY	REV: B

REV/ECN NO OR DESCRIPTION	REVISED	DATE
A PRODUCT RELEASE	MKE	2011.10.25
B MODIFY	BROKEN	2015.03.17

- NOTE:
- ELECTRICAL CHARACTERISTICS
 - 1-1. VOLTAGE RATING:30V AC
 - 1-2. CURRENT RATING:2.0A
 - 1-3. CONTACT RESISTANCE: 50 milliohms MAX.
 - 1-4. INSULATION RESISTANCE: 100 Megohms MIN.
 - 1-5. DIELECTRIC WITHSTANDING VOLTAGE: 500V AC FOR 1 MINUTE.
 - MECHANICAL CHARACTERISTICS
 - 2-1. MATING&UMATING FORCE: 1.0kgf~2.0kgf
 - 2-2. DURIBLITY:10000CYCLES
 - 3. SALT SPRAY: 24H
 - 4. OPERATING TEMPERATURE:-40°C~85°C
 - 5. ROHS 2002/95/EC COMPLIANT.
 - 6. CRITICAL DIMENSIONS : ▽