

THIS INFORMATION IS CONFIDENTIAL AND IS DISCLOSED TO YOU ON CONDITION THAT NO FURTHER DISCLOSURE IS MADE BY YOU TO OTHER THAN TETULL PERSONNEL WITHOUT WRITTEN AUTHORIZATION FROM TETULL LTD.

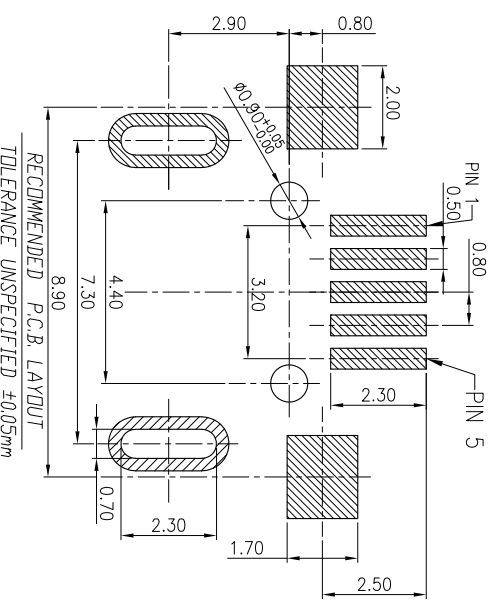
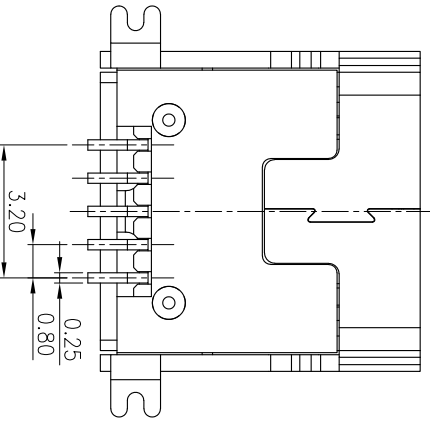
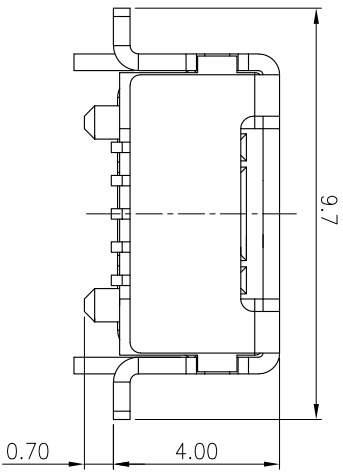
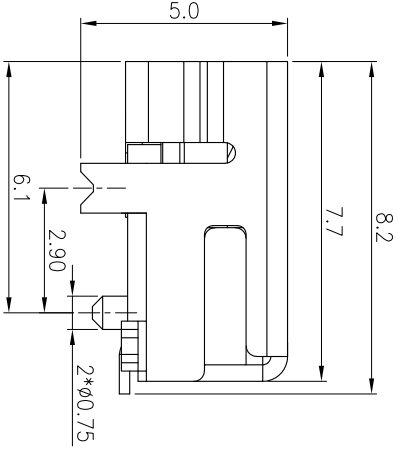
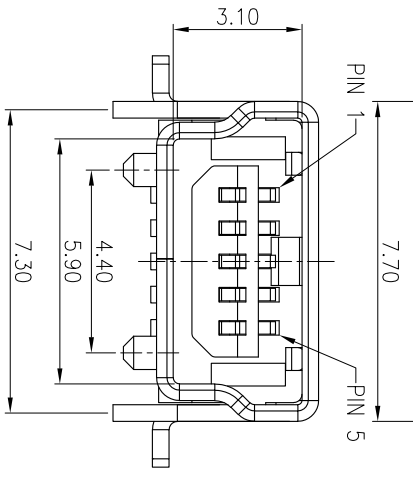
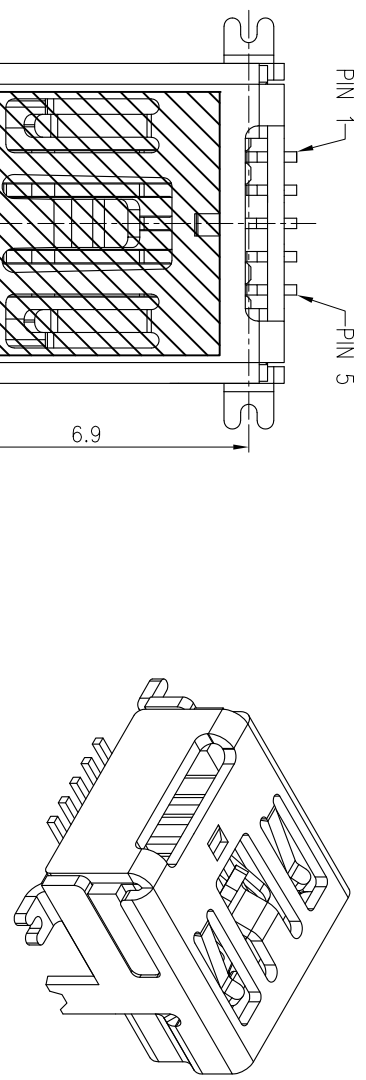

C	SHIELD	1	COPPER ALLOY	Ni&Ti PLATED
B	TERMINAL	5	COPPER ALLOY	Gold Flash On Contact Area Tin plated on Solder tail All over Nickel Plated.
A	HOUSING	1	THERMOPLASTIC UL94-V0	BLACK
NO	DESCRIPTION	QTY	MATERIAL	PLATING & COLOR

UNLESS OTHERWISE SPECIFIED TOLERANCES		TITLE: Mini usb FM 5P DIP+SMT TYPE	
DECIMALS:	ANGLES:	PART NO.	1030502AR004
X.XX :±0.5	X.XX :±2°	DWN	JAMES
X.XX :±0.3	X.XX :±1°	CHKD	2015.09.25
X.XX :±0.2		APVD	
RECOMMENDED P.C.B. LAYOUT TOLERANCE UNSPECIFIED ±0.05mm		SCALE 1:1	UNIT: mm
		SIZE: A4	SHEET: 10F1

NOTE:

- ELECTRICAL CHARACTERISTICS
  - 1-1. VOLTAGE RATING: 30V AC
  - 1-2. CURRENT RATING: 1.0A
  - 1-3. CONTACT RESISTANCE: 50 milliohms MAX.
  - 1-4. INSULATION RESISTANCE: 100 Megohms MIN.
  - 1-5. DIELECTRIC WITHSTANDING VOLTAGE: 500V AC FOR 1 MINUTE.
- MECHANICAL CHARACTERISTICS
  - 2-1. MATING&UNMATING FORCE: 0.7kgf~3.5kgf
  - 2-2. DURABILITY: 5000 CYCLES
  - 3. SALT SPRAY: 24H
  - 4. OPERATING TEMPERATURE: -40°C~85°C
  - 5. ROHS 2002/95/EC COMPLIANT.
  - 6. MPQ : 700PCS/REEL.

SHELL	SHIELD
5	GND
4	ID
3	D+
2	D-
1	VBUS
	PIN NAME
	PIN ASSIGNMENT

REV.	ECN NO OR DESCRIPTION	REVISED	DATE
A	PRODUCT RELEASE	JAMES	2015.09.25