

THIS INFORMATION IS CONFIDENTIAL AND IS DISCLOSED TO YOU ON CONDITION THAT NO FURTHER DISCLOSURE IS MADE BY YOU TO OTHER THAN TETULL PERSONNEL WITHOUT WRITTEN AUTHORIZATION FROM TETULL LTD.

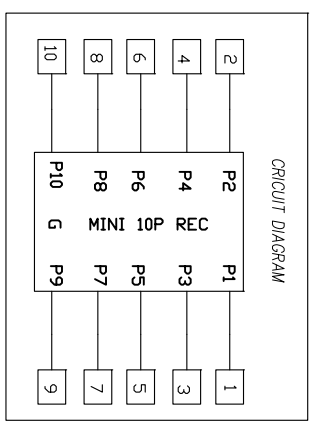
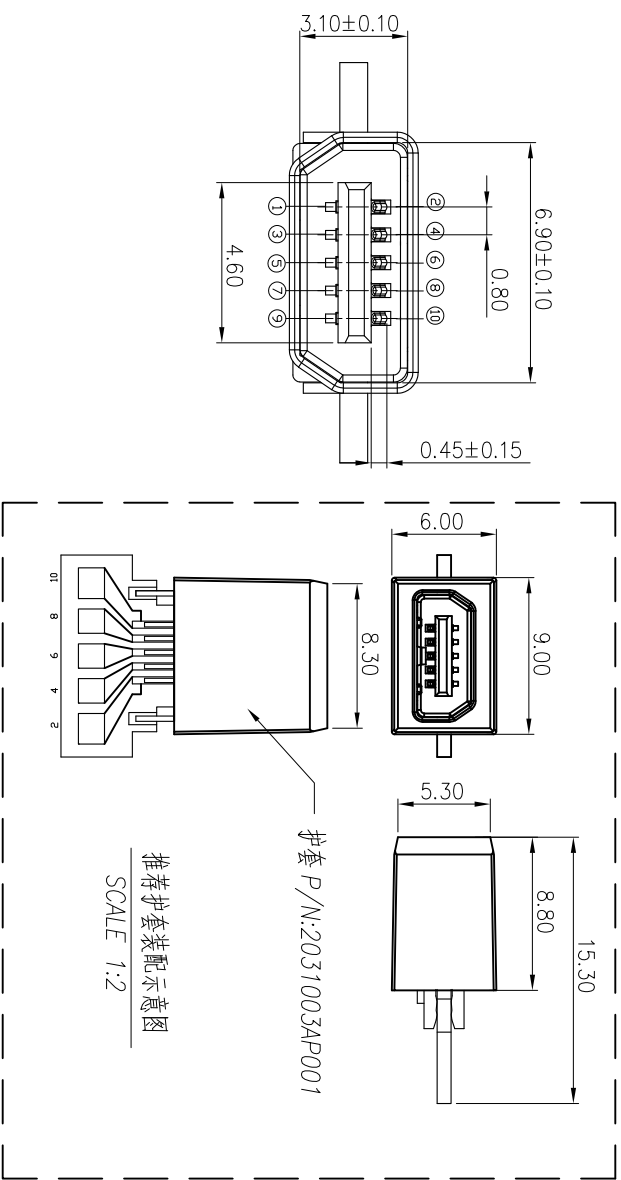
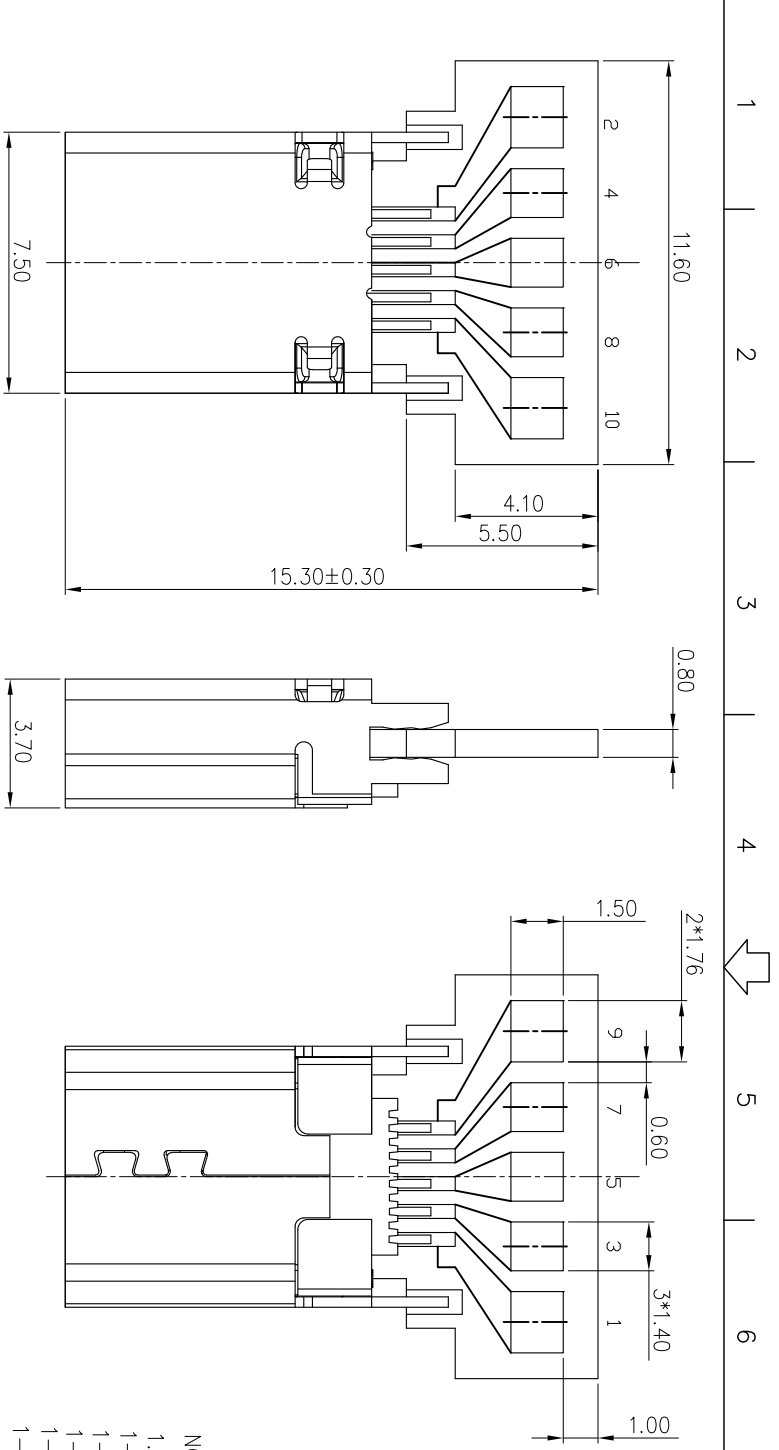

- NOTE:
- ELECTRICAL CHARACTERISTICS
 - 1-1. VOLTAGE RATING:30V AC
 - 1-2. CURRENT RATING:2.0A
 - 1-3. CONTACT RESISTANCE: 50 milliohms MAX.
 - 1-4. INSULATION RESISTANCE: 100 Megohms MIN.
 - 1-5. DIELECTRIC WITHSTANDING VOLTAGE: 500V AC FOR 1 MINUTE.
 - MECHANICAL CHARACTERISTICS
 - 2-1. Mating FORCE: 35N Max
 - 2-2. Unmating FORCE: 7N Min(Initial)
 - 2-3. DURIBILITY:10000CYCLES
 - 3. OPERATING TEMPERATURE:-40°C~85°C

D	PCB	1	FR-4	T-051
C	SHELL	1	STAINLESS STEEL 0.30t	N: PLATING
B	CONTACT	10	COPPER ALLOY 0.15t	Gold Flash On Contact Area Tin plated on Solder tail All over Nickel Plated.
A	HOUSING	1	THERMOPLASTIC U94-10	BLACK
NO	DESCRIPTION	QTY	MATERIAL	PLATING & COLOR

UNLESS OTHERWISE SPECIFIED TOLERANCES

DECIMALS: ANGLES:

X : ±0.5 X : ±2°
 X.X : ±0.3 X.X : ±1°
 X.XX : ±0.2

REV	ECN NO	OR DESCRIPTION	REVISED	DATE
A		PRODUCT RELEASE	BROKEN	2023.06.21
B		增加护套装配示意图	ZHARKO	2023.11.13

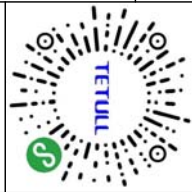

TITLE: MINI USB 10P每座不锈钢壳10焊点测试板

MINT USB 10P每座不锈钢壳10焊点测试板

PART NO.	1031003AR016
DMW	ZHARKO
CHKD	2023.11.13
APVD	

SCALE 1:1 UNIT: mm

CUSTOMER COPY SIZE: A4 SHEET: 10F1 REV: B